

- 1 *Electrochemical lab*
- 2 *Ductile amorphous Fe-Ni ribbons*
- 3 *3D-Structured electrode*

## ELECTRODE MATERIALS FOR ALKALINE WATER ELECTROLYSIS

### Fraunhofer Institute for Manufacturing Technology and Advanced Materials IFAM Branch Lab Dresden

Winterbergstrasse 28  
01277 Dresden | Germany

#### Contact

Dr. rer. nat. Lars Röntzsch  
Phone: +49 351 2537 411  
E-mail: Lars.Roentzsch  
@ifam-dd.fraunhofer.de

Dr. rer. nat. Christian Immanuel Müller  
Phone: +49 351 2537 416  
E-mail: Christian.Mueller  
@ifam-dd.fraunhofer.de

Fax: +49 351 2537 399

[www.ifam.fraunhofer.de/h2](http://www.ifam.fraunhofer.de/h2)



### Sustainable H<sub>2</sub> Production by Water Electrolysis

In view of the shortage of fossil energy resources, hydrogen is becoming an important energy carrier because it can be produced directly from renewable energy sources by water electrolysis. It is mandatory to provide 'green' hydrogen at low cost in order to build up a hydrogen energy cycle for a sustainable and environmentally friendly economy.

At Fraunhofer IFAM Dresden, new electrode materials for electrolysis are fabricated and tested regarding their electrochemical, structural and mechanical properties. Focusing on alkaline water electrolysis the materials are designed in order to increase the efficiency of both the hydrogen (HER) and the oxygen evolution reaction (OER). Different aspects have to be considered to increase the efficiency: long-term stability, high electrocatalytic activity, high surface area and the management of the gas flow.



### Alloyed Electrodes

Metal alloys can be produced as foils and ribbons by melt spinning. The desired electrochemical and mechanical properties can be adjusted by the composition of the alloys and the processing conditions.

- 20-80 µm in thickness
- homogeneous element distribution
- nanocrystalline
- Fe- and Ni-base alloys



### 3D-Structured Electrodes

Porous materials offer the possibility to enlarge the surface area of the electrode and to manage the gas flow. Both aspects depend on the pore size. At Fraunhofer IFAM Dresden alloyed Fe- and Ni-meshes as well as fleeces can be produced.

- pore size: 5 - 1200 µm
- porosity: 50 - 95 %

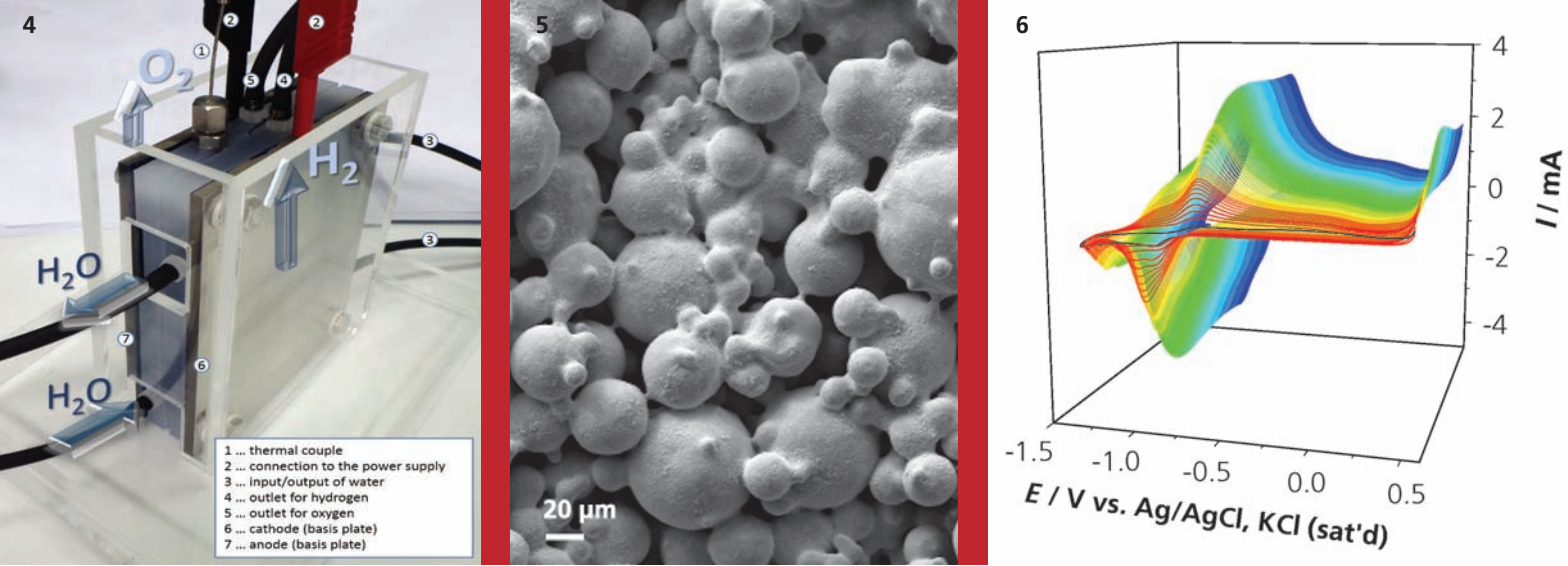

## Electrochemical and Structural Evaluation

For the development and improvement of high-performance electrode materials it is mandatory to elucidate the structure-property relationships of the materials. At Fraunhofer IFAM Dresden state-of-the-art electrochemical analysis equipment, e.g. electrochemical scanning tunneling microscopy (EC-STM), are available in order to investigate the electrochemical properties and the surface morphology of the electrode materials.

Analysis techniques:

- Electrochemical analysis
  - Cyclic voltammetry (CV)
  - Impedance spectroscopy (EIS)
  - Polarization methods
- Scanning tunneling microscopy (STM)
- Electrochemical STM (EC-STM) and scanning electrochemical potential mapping (SECPM) for *in situ* experiments

## Testing the Electrode Materials in an Electrolyzer

The electrode materials are tested under realistic operation conditions (80°C, 7.6 M KOH) to demonstrate their applicability. Therefore, the electrodes are integrated into lab-scale electrolyzer cells, which are designed to measure the electrical energy consumption per generated hydrogen volume. Due to the simplicity of the system different electrode configurations can be easily realized.

Prototype-Parameters:

- One cell design
- Operating conditions
  - 80°C
  - 7.6 M KOH
  - 5 Ni-H<sub>2</sub>/h
  - atmospheric pressure

- 4 Lab-scale electrolyzer
- 5 Tailored surface structure
- 6 Multi-cycling voltammetry of an amorphous Fe-Co ribbon

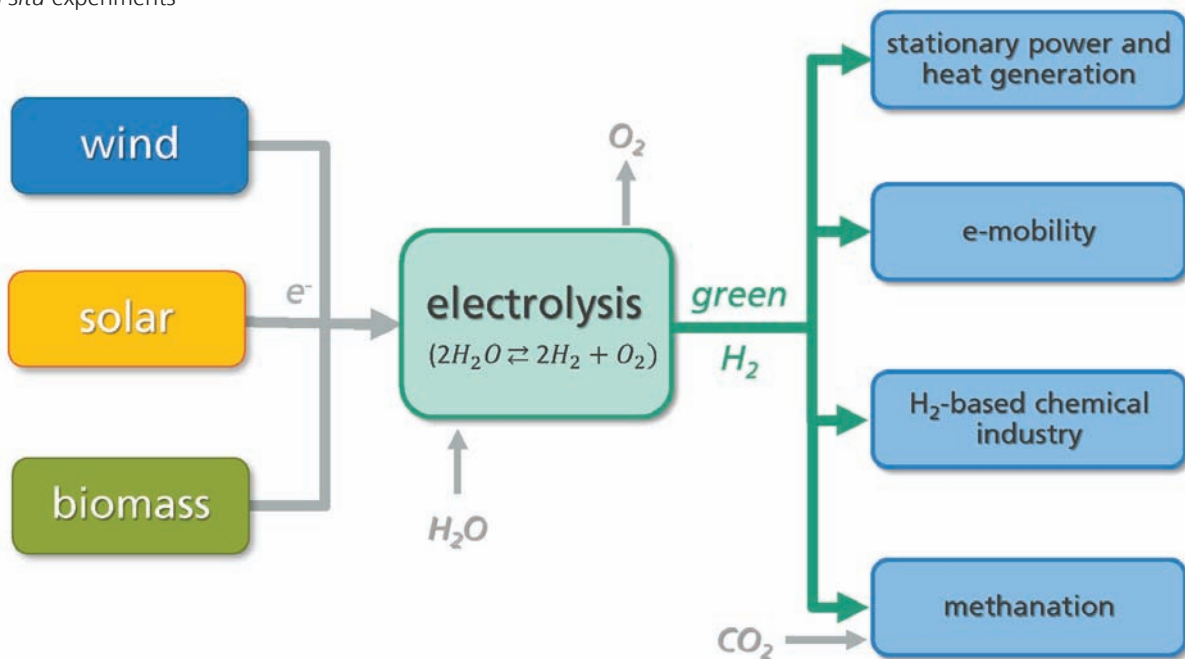

Fig. 1: Schematic of 'green' hydrogen production by alkaline water electrolysis and hydrogen utilization